

CONTENTS

1. INTRODUCTION	1
2. SAFTY INSTRUCTION.....	2
3. CABLE CONNECTION.....	4
4. SYSTEM DESCRIPTION.....	5
5. INVERTER OPERATION	11
6. TROUBLE SHOOTING GUIDE.....	16
7. OPERATION MODES OF THE INVERTER	18
8. SPECIFICATION OF INVERTER.....	20
9. NEW LCD SETTINGS.....	24

1. INTRODUCTION

1.1 General Description

The pure sine wave Inverter, a powerful all-in-one solution, delivers unsurpassed clean true sine wave output power and combines this with a selectable multistage battery charging current. Applicable for any kind of loads, such as air conditioner, home appliances, consumer electronic and office equipments. This series features a durable & continuous 24 operation. The built-in 5-stage intelligent charger automatically charges any type of batteries without the risk of overcharge. The compact & modular design makes utility interactive installations easier and more cost effective. It is a high quality product that offers the best price/performance ratio in the industry.

1.2 Key features

1. Multiple microprocessor design base.
2. Compatible with both linear&non-linear load.
3. Stronger charger to support batteries of 600AH up.
4. 24 hours operation on the inverter.
5. DC start and automatic self-diagnostic function.
6. THD less than 3%.
7. High efficiency design to save electricity.
8. Low heat dissipation in long time operation
9. Design to operate under harsh environment
- 10 3U 19" Rack Mount or WALL Mounted design

1.3 Important Notices

1. Read instructions carefully before operating the Inverter.
2. INVERTER power connect instruction should be followed.
3. Please don't open the case to prevent danger.
5. Retain the load within the rating of INVERTER to prevent faults.
6. Keep the INVERTER clean and dry.

2. SAFTY INSTRUCTION

2.1 Transporting

1. Disconnect all power cables if necessary.
2. Be careful not to damage the INVERTER while transporting.
3. Don't move the INVERTER upside down.
4. Please transport the INVERTER system only in the original packaging (to protect against shock and impact).

2.2 Positioning

1. Do not put the INVERTER on rugged or declined surface.
2. Do not install the INVERTER system near water or in damp environments.
3. Do not install the INVERTER system where it would be exposed to direct sunlight or near heat.
4. Do not block off ventilation openings in the INVERTER system's housing and don't leave objects on the top of the INVERTER.
5. Keep the INVERTER far away from heat emitting sources.
6. Do not expose it to corrosive gas.
7. Ambient temperature : 0°C - 40°C

2.3 Installation

1. Connect the INVERTER system only to an earthed shockproof socket outlet.
2. Place cables in such a way that no one can step on or trip over them.

2.4 Operation

1. Do not disconnect the mains cable on the INVERTER system or the building wiring socket outlet during operations since this would cancel the protective earth of the INVERTER system and of all connected loads.
2. The INVERTER has its own internal power source (batteries). The output terminals may be live even when the INVERTER is not connected to the AC supply.
3. Ensure that no fluids or other foreign objects can enter the INVERTER system.

2.5 Maintenance and Service

1. Caution - risk of electric shock.

Even after the unit is disconnected from the mains power supply (building wiring socket outlet), components inside the INVERTER system are still connected to the battery and are still electrically live and dangerous. Before carrying out any kind of servicing and/or maintenance, disconnect the batteries and verify that no current is present.

2. Batteries may cause electric shock and have a high short-circuit current. Please take the precautionary measures specified below and any other measures necessary when working with batteries:
 - remove wristwatches, rings and other metal objects
 - use only tools with insulated grips and handles.

3. CABLE CONNECTION

3.1 Inspection

1. The system may be installed and wired only by qualified electricians in accordance with applicable safety regulations.
2. When installing the electrical wiring, please note the nominal amperage of your incoming feeder.
3. Inspect the packaging carton and its contents for damage. Please inform the transport agency immediately should you find signs of damage. Please keep the packaging in a safe place for future use.
4. Please ensure that the incoming feeder is isolated and secured to prevent it from being switched back on again.

3.2 Connection

The INVERTER is connected with terminal blocks to AC main and the loads, please use a proper rating of the power cord.

4. SYSTEM DESCRIPTION

4.1 Front Panel Description for LCD Model

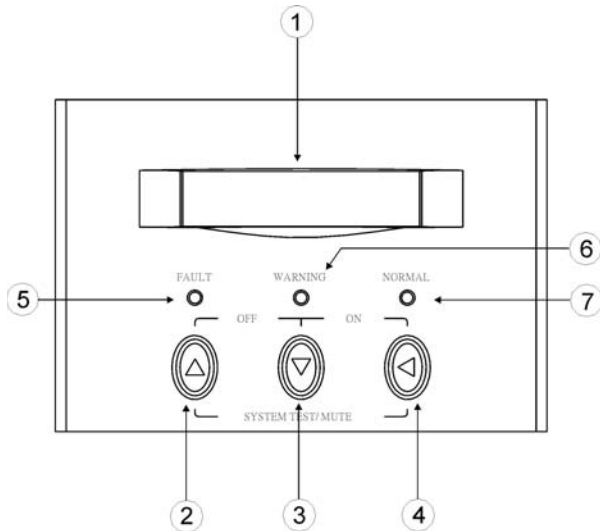

1. LCD Display: This indicates the INVERTER operation information, including INVERTER status, input/output voltage, input/output frequency, battery voltage, battery capacity left, output load, inside temperature, and the times of history events.
2. Up-key: Use to select upward the INVERTER status on LCD Display.
3. Down-key: Use to select downward the INVERTER status on LCD Display. Beside, press it simultaneously with the Up-key to switch off the INVERTER.
4. Enter-Key: It is pressed with the Down-key to turn on the INVERTER. In battery operation mode, press it with Up-key at the same time to disable the buzzer. Beside, it is pressed to confirm and enter the item selected.
5. Fault LED (red): To indicate the INVERTER is in fault condition because of inverter shutdown or over-temperature.

6. Warning LED (yellow): To indicate the INVERTER is in the status of overload, bypass and battery back-up.
7. Normal LED (green): To indicate the INVERTER is operating normally.
8. ON/TEST/MUTE key: It should be pressed with the control key simultaneously to switch on INVERTER, do INVERTER auto-test in normal AC mode and turn off the buzzer in battery operation.

4.2 Outline Description

1.2KVA Wall Mounted Type

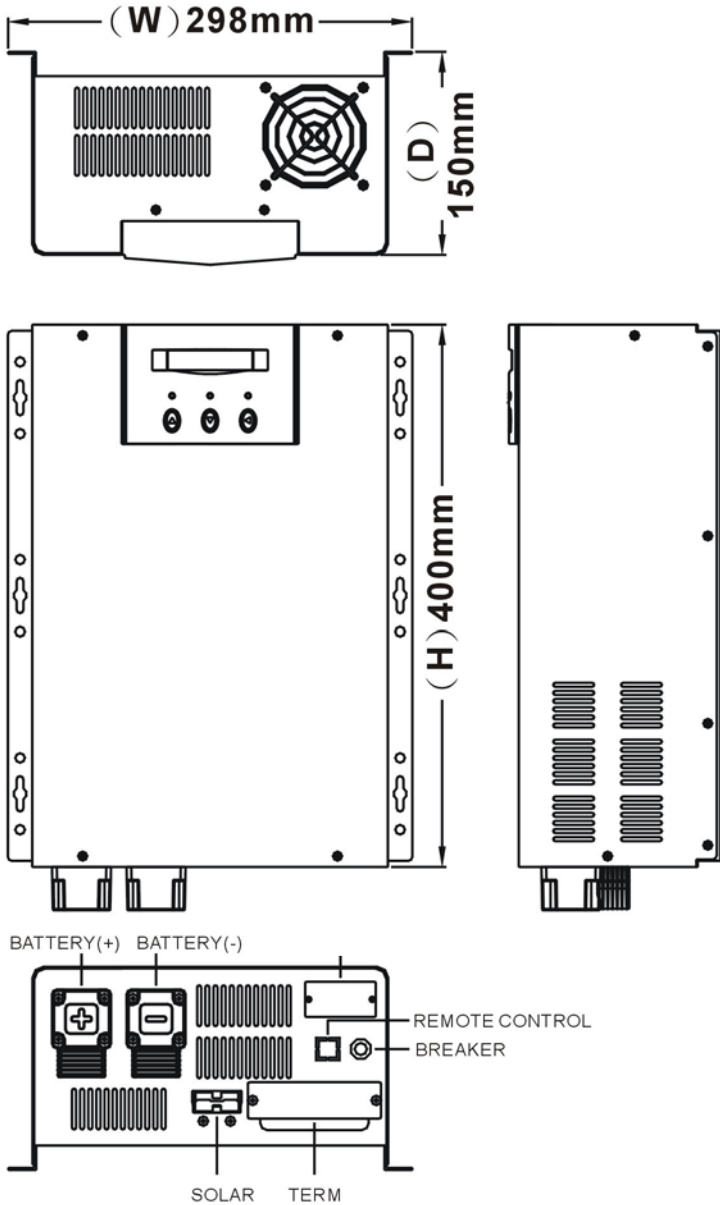

2.4KVA / 3.6KVA Wall Mounted Type

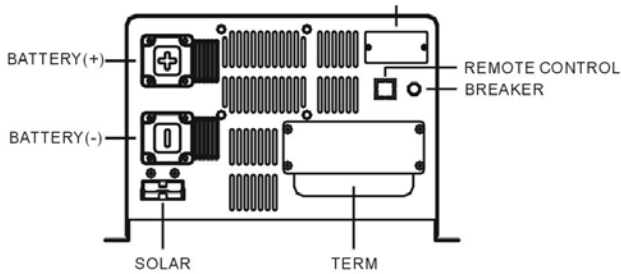
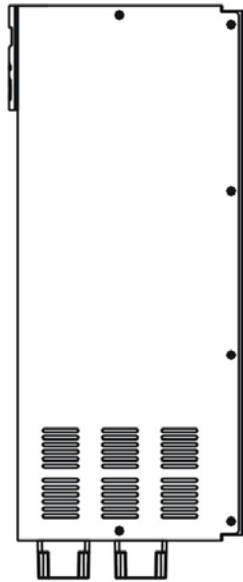
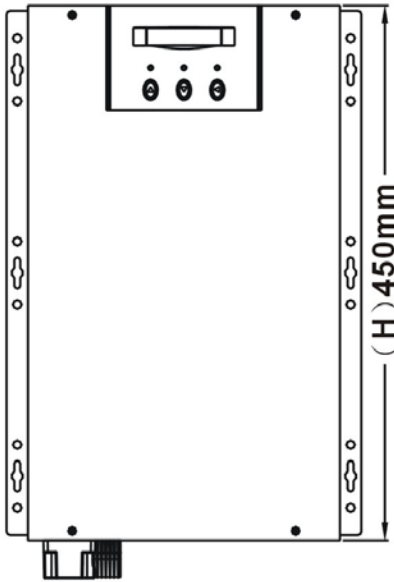
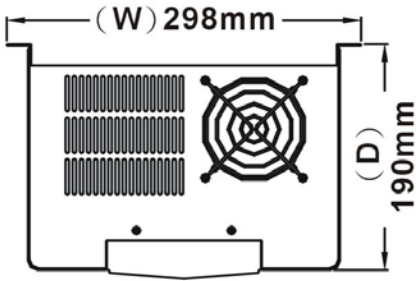

5KVA / 6KVA / 8KVA Wall Mounted Type

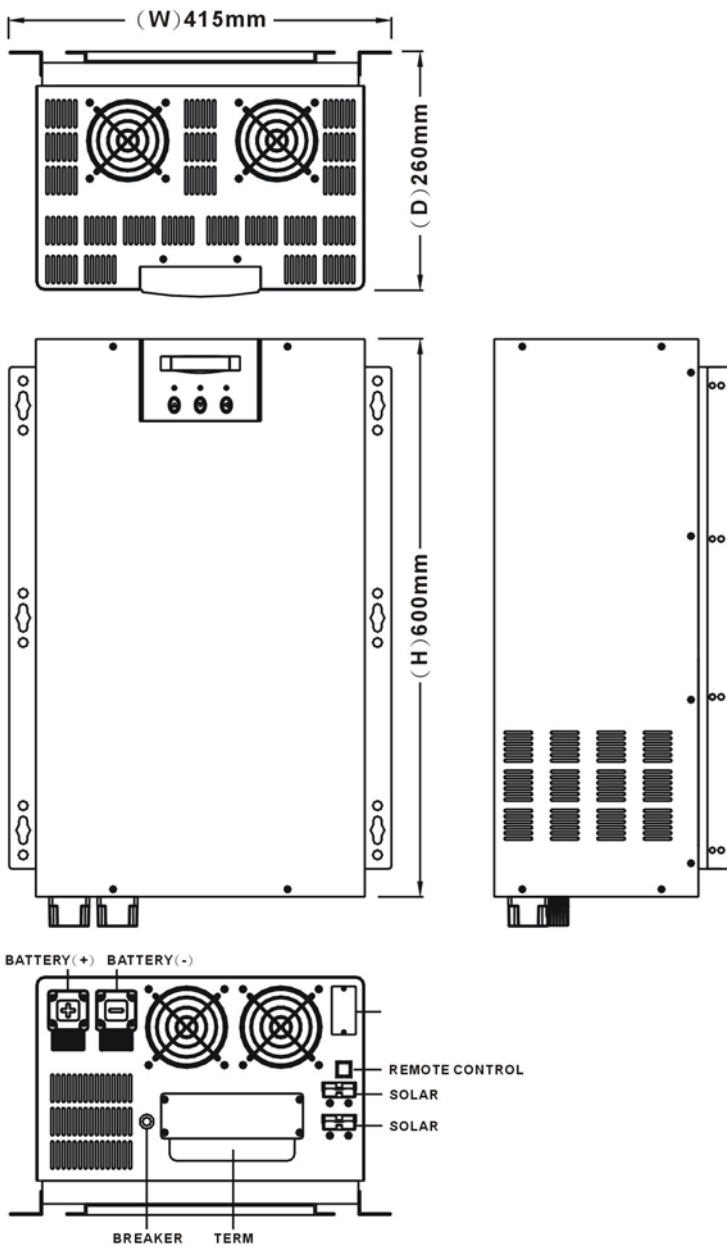

5. INVERTER OPERATION

5.1 Check Prior to Start Up

1. Ensure the INVERTER is in a suitable positioning.
2. Check input cord is secured.
3. Make sure the load is disconnected or in the "OFF" position.
4. Check if input voltage meets the INVERTER rating required.

5.2 Storage Instruction

Disconnect input power in rear panel if you will not use it for long period. If the INVERTER is stored over 3 months, please keep supplying power to the INVERTER for at least 24 hours to ensure battery fully recharged.

5.3 Operation Procedure for LCD Model

Please follow the instructions below for INVERTER operation.

1. Once the AC source is connected, the LCD Display shall light up immediately (8~10 seconds in main menu of greeting context) to standby for INVERTER startup.

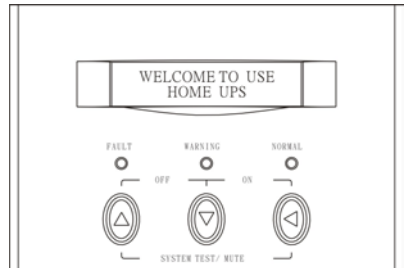

2. By pressing the Enter-key and the Down-key simultaneously for 3 seconds, the INVERTER will start up after two beeps and Normal LED lights up to indicate the power is from its bypass AC main to the load.
3. When the Down-key and the Up-key are pressed simultaneously for 3 seconds, the INVERTER will be turned off after two beeps.

4. LCD Display Menu

Use Up/Down key to select menu-displays of the LCD described below. This screen will refresh once the system power is enabled.

Rated Spec

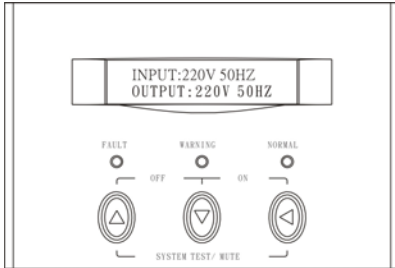

Status

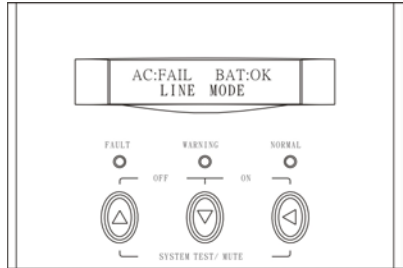

Voltage

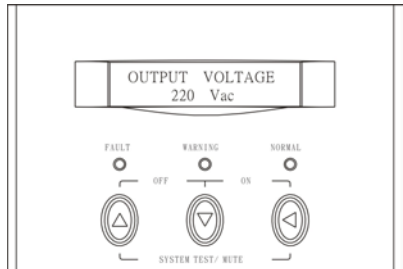
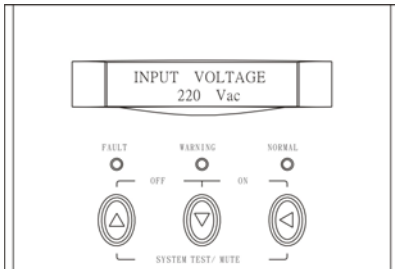

Frequency

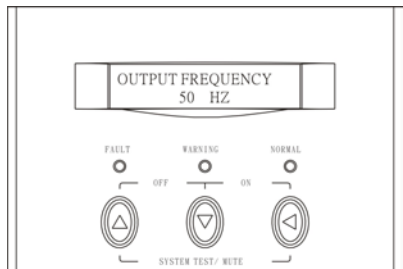
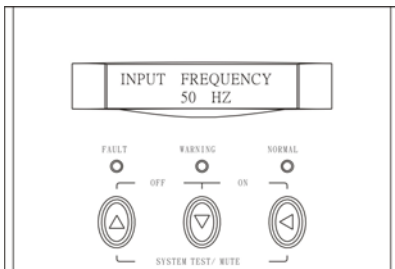

Battery Status

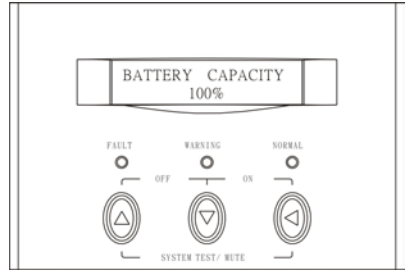
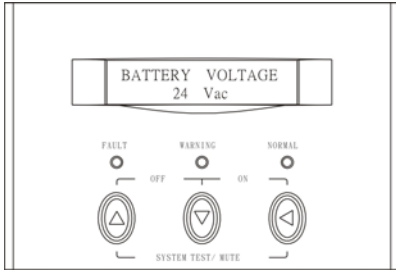

Output Power

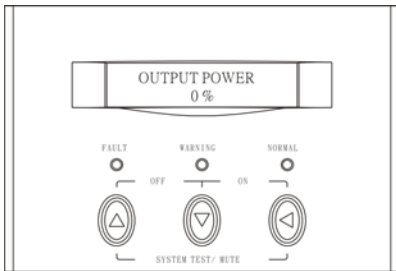

Temperature

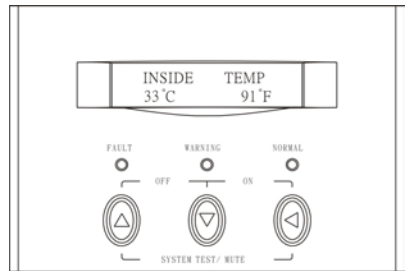

History Record

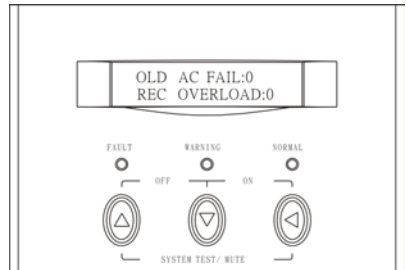
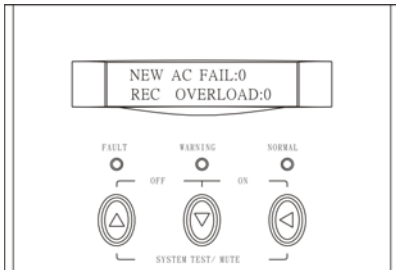

5. Output setting

After INVERTER startup, press the Down-key to find the screen and then press Enter-key for setting.

Output Voltage & Frequency Adjust

A. In this screen, press Enter-key to enter the following steps for output voltage and frequency adjustment.

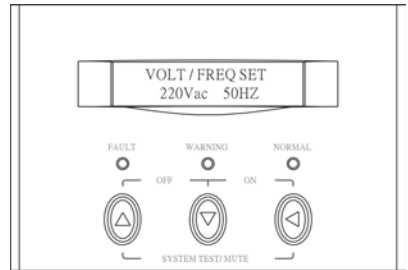

B. The cursor (→) will pop up to indicate the output voltage and frequency newly selected.

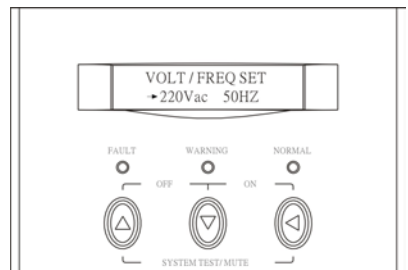

C. Use Up or Down-key to adjust the output voltage (if 220V configure, 220V, 230V, and 240V is selectable; if 110V configure, 110V, 115V, and 120V is selectable). Press Enter-key to confirm voltage and then the cursor will move to frequency selection. The output frequency (50Hz or 60Hz) can be adjusted by the same key operation.

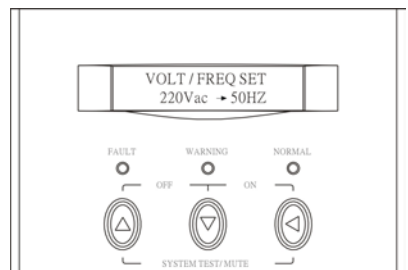

D. Once the correct voltage is selected, press Enter-key again to save the selection.

6. Battery AH setting

Battery AH Adjust

A. In this screen, press Enter-key to enter the following steps for general battery AH adjustment.

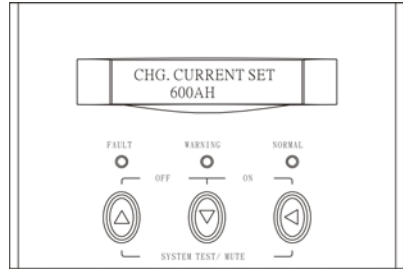

B. The cursor (→) will pop up to indicate the battery AH newly selected.

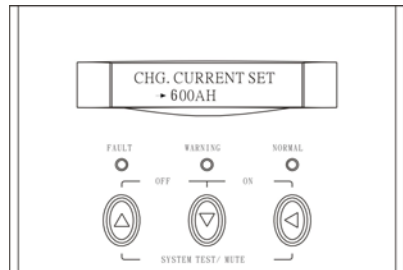

C. Use Up or Down-key to select the battery AH (100AH, 200AH, 300AH, 400AH, and 600AH selectable). Press Enter-key to confirm your battery AH.

D. Once the correct battery AH is selected, press Enter-key again to save the selection.

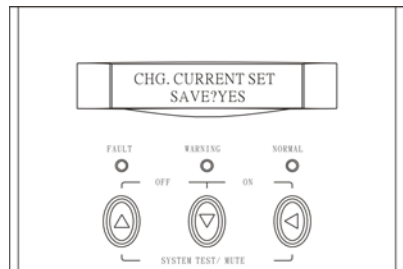

6. TROUBLE SHOOTING GUIDE

6.1 For LCD Model

The following guideline may be helpful for basic problem solving.

No.	INVERTER STATUS	POSSIBLE CAUSE	ACTION
1	AC utility power is normal. INVERTER is running normally, but fault LED lits up. Buzzer beeps continuously.	<ol style="list-style-type: none"> 1. Charger PCB is damaged. 2. Fan is damaged. 3. Unknown 	<ol style="list-style-type: none"> 1. Replace the charger PCB. 2. Replace the fan. 3. Restart INVERTER
3	AC utility power is normal but INVERTER is overloaded. Warning LED lits up and buzzer beeps per second.	Overload 100%< load< 125%	Please reduce the critical load to <100%.
4	AC utility power is normal. Warning LED does not fade out and buzzer beeps per 0.5 second.	Overload 125%< load<150%	Please reduce the critical load to <100%.
5	AC utility power is normal. Warning LED lits up and buzzer beeps continuously.	Overload 150%< load	Please reduce the critical load to <100%.

No.	INVERTER STATUS	POSSIBLE CAUSE	ACTION
6	AC utility power fails .The load is supplied by battery power. Buzzer alarm sounds every 4 seconds.	1. AC utility power failure. 2. AC input connection may be not correct.	1. Reduce the less critical load in order to extend backup time. 2. Please check the rated input or connected line.
7	AC utility fails. INVERTER is in battery backup mode. Buzzer alarm beeps every second.	Battery power is approaching low level.	INVERTER will shut down automatically. Please save data or turn off the loads soon.
8	AC utility power fails. INVERTER has shut down automatically.	Battery runs out	INVERTER will restart up when AC utility power is restored.

7. OPERATION MODES OF THE INVERTER

7.1 INVERTER System Block Diagram

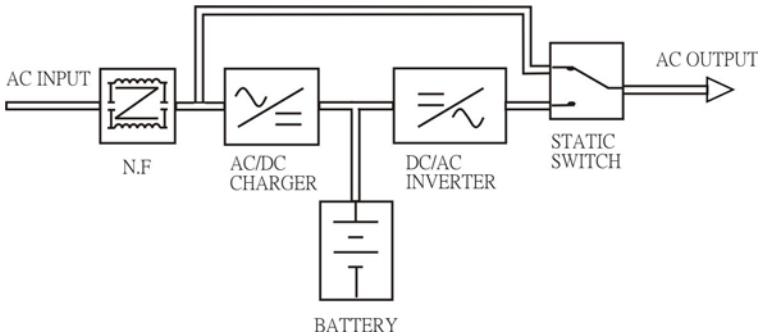

7.2 Normal Operation

There are two main loops when AC utility is normal: the AC loop and the battery charging loop. The AC output power comes from AC utility input and passes through static switch to support power to load. The battery charging voltage comes from AC utility input and converted by AC/DC charger to support battery-charging power.

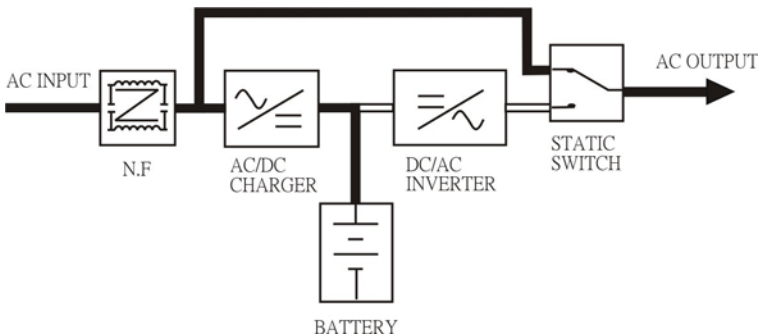

7.3 AC Utility Failure (Battery Mode)

The AC output comes from battery, passing through DC/AC inverter and static switch within the battery backup time.

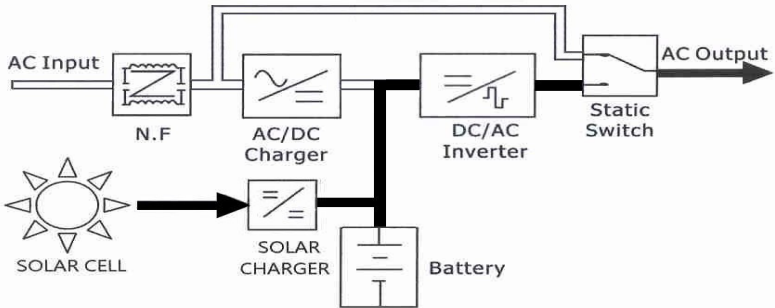
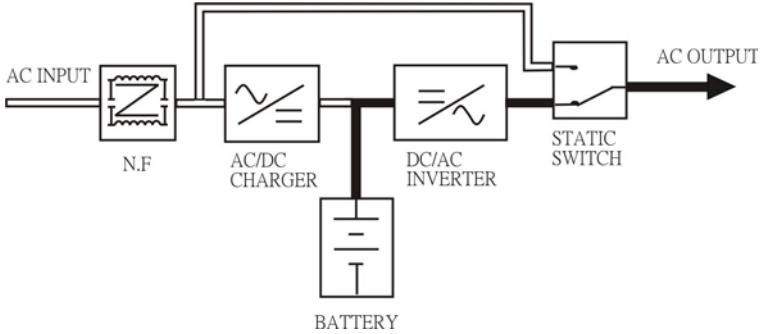

SOLAR 50A Charger Specification

Normal DC	12V	24V	48V
Charging Voltage	13.8V	27.6V	55.2V
Operating High Voltage	25V	50V	100V
Operating Low Voltage	12V	24V	44V
Maximum Charging Curr	50A	50A	50A
Polarity Reverse Protector	OK	OK	OK
Current Reverse Protector	OK	OK	OK

8. SPECIFICATION OF INVERTER

Model		MS-PSI-1.2K	MS-PSI-2.4K	MS-PSI-3.6K	
Capacity	VA / Watt	1.2KVA / 800W	2.4KVA / 1600W	3.6KVA / 2400W	
Input	Nominal Voltage		220Vac; 110Vac		
	Voltage Range	Acceptable Voltage Range	120-275Vac ; 60-135Vac		
		Frequency	50Hz / 60Hz (45Hz - 70Hz)		
		Line Low Transfer	120VAC \pm 2% ; 60VAC \pm 2%		
		Line Low Return	130VAC \pm 2% ; 65VAC \pm 2%		
		Line High Transfer	275VAC \pm 2% ; 135VAC \pm 2%		
		Line High Return	260VAC \pm 2% ; 130VAC \pm 2%		
Output	Voltage		220Vac (230V or 240VAC re-settable via LCD panel 110Vac (115V or 120VAC re-settable via LCD panel)		
	Voltage Regulation (Batt. Mode)		< 3% RMS for entire battery voltage range		
	Frequency		50Hz or 60Hz		
	Frequency Regulation (Batt. Mode)		\pm 0.1Hz		
	Power Factor		0.67		
	Waveform		Pure Sinewave		
	Efficiency		> 75%	> 80%	
	Overload Protection	Line Mode	Circuit Breaker		
Battery Mode		110% ~ 150% for 30 sec. , >150% for 200ms			
Transfer Time	Typical	< 8 ms.			

Model		MS-PSI-1.2K	MS-PSI-2.4K	MS-PSI-3.6K
Capacity	VA / Watt	1.2KVA / 900W	2.4KVA / 1600W	3.6KVA / 2400W
Battery	Battery Voltage	24Vdc; 12Vdc special	24Vdc	24Vdc
	Backup Time (at full load)	long time available		
	Max. Charging Current (5 steps selectable)	> 40A	> 50A	
Display LCD	LCD	INVERTER status, I/P&O/P Voltage Frequency, Load%, Battery Voltage & %, Charge current, Temperature, Model		
	LED	Normal (Green), Warning (Yellow), Fault (Red)		
Audible Alarm	Battery Mode	Beeping every 4 seconds		
	Low Battery	Beeping every second		
	INVERTER Fault	Beeping Continuously		
	Overload	Beeping twice per second		
Environment	Operation Temperature	0-40 degree C; 32-104 degree F		
	Relative Humidity	0-95% non-condensing		
	Audible Noise	Less than 55dBA (at 1M)		
Physical	Net Weigh (Kgs)	14	21	23
	(WxHxD)mm Wall Mounted	298*400*150	298*450*190	298*450*190

- Specifications are subjected to change without prior notice.

Model		MS-PSI-5.0K	MS-PSI-6.0K	MS-PSI-8.0K	
Capacity	VA / Watt	5KVA / 4000W	6KVA / 6000W	8KVA / 8000W	
Input	Nominal Voltage		220Vac; 110Vac		220Vac only
	Voltage Range	Acceptable Voltage Range	120-275Vac ; 60-135Vac		120-275Vac
		Frequency	50Hz / 60Hz (45Hz - 70Hz)		50Hz / 60Hz (45Hz - 70Hz)
		Line Low Transfer	120VAC \pm 2% ; 60VAC \pm 2%		120VAC \pm 2%
		Line Low Return	130VAC \pm 2% ; 65VAC \pm 2%		130VAC \pm 2%
		Line High Transfer	275VAC \pm 2% ; 135VAC \pm 2%		275VAC \pm 2%
		Line High Return	260VAC \pm 2% ; 130VAC \pm 2%		260VAC \pm 2%
Output	Voltage		220Vac (230V or 240VAC re-settable via LCD panel) 110Vac (115V or 120VAC re-settable via LCD panel)		
	Voltage Regulation (Batt. Mode)		< 3% RMS for entire battery voltage range		
	Frequency		50Hz or 60Hz		
	Frequency Regulation (Batt. Mode)		\pm 0.1Hz		
	Power Factor		0.8	1.0	
	Waveform		Pure Sinewave		
	Efficiency		> 80%		
	Overload Protection	Line Mode	Circuit Breaker		
Battery Mode		110% ~ 150% for 30 sec. , >150% for 200ms			
Transfer Time	Typical	< 8 ms.			

Model		MS-PSI-5.0K	MS-PSI-6.0K	MS-PSI-8.0K
Capacity	5KVA / 4000W	5KVA / 4000W	6KVA / 6000W	8KVA / 8000W
Battery	Battery Voltage	24Vdc	48Vdc	
	Backup Time (at full load)	long time available		
	Max. Charging Current (5 steps selectable)	> 50A	> 60A	
Display LCD	LCD	INVERTER status, I/P&O/P Voltage Frequency, Load%, Battery Voltage & %, Charge current, Temperature, Model		
	LED	Normal (Green), Warning (Yellow), Fault (Red)		
Audible Alarm	Battery Mode	Beeping every 4 seconds		
	Low Battery	Beeping every second		
	INVERTER Fault	Beeping Continuously		
	Overload	Beeping twice per second		
Environment	Operation Temperature	0-40 degree C; 32-104 degree F		
	Relative Humidity	0-95% non-condensing		
	Audible Noise	Less than 55dBA (at 1M)		
Physical	Net Weigh (Kgs)	49.2Kg	51.4Kg	53.6Kg
	(WxHxD)mm Wall Mounted	415*600*260	415*600*260	415*600*260

- Specifications are subjected to change without prior notice.

9. NEW LCD SETTINGS

1. I / P Voltage Range Setting	
	Default : Input Voltage : LO = 170V, HI = 270V. Input Frequency : 45Hz~ 70Hz
	LO : 120V ~ 200V (One Touch: +/- 1V)
	HI : 250V ~ 280V (One Touch: +/- 1V)
	Mark : 1. Return point= +/- 10V from the transfer point.
	2. Press Enter to enable the setting. No need to re-start the inverter.
2. O/P Voltage /Frequency Setting	
	Default: 220VAC , 50HZ
	Voltge: 220VAC / 230VAC / 240VAC Selectable
	Frequency: AC= Synchronized to AC., DC= 50HZ / 60HZ Selectable
	Mark : Press Enter to confirm. Need to re-start the inverter to Enable the setting.
3. AC/DC Prior Setting (Optional) Functioning only under AC Mode.	
	Default: AC Prior.
	Select "AC MODE" for AC Prior ., "INVERTER MODE" for DC Prior.
	Mark:1. When the inverter is set to "DC Prior", if the inverter itself diagnoses problems, it will auto change to AC if AC normal.
	2. Press Enter to confirm. Need to re-start the inverter to Enable the setting.
4.Green Power On/Off Setting (Optional) Functioning only under INVERTER Mode.	
	Default: Off.
	Green Power Off: System running continuously.
	Green Power On: System Auto Shutdown when Load < Pre-setting
	Mark : Press Enter to enable the setting. No need to re-start the inverter.
5.Green Power Load & Time Setting (Optional)	
	Default: Time period for next detecting: 30 Sec.
	Time: 15 Sec., 30 Sec., 45 Sec. 60 Sec selectable.
	Mark:1. Detecting load: 5~10VA
	2. When the load is less than 5~10VA,the inverter will auto turn off and count the pre-set time (30 Sec.),then, re-start.
	3. Press Enter to enable the setting. No need to re-start the inverter.
6.Battery Shutdown Voltage & Current Setting (48V / 24V)	

	Default: 40V (20V).
	HIGH: 42V (21V) / MIDDLE: 40V (20V) / LOW :38V (19V) Selectable
	Mark:1. Low Voltage warning point: 42.5 V (21.5V)
	2. Press Enter to enable the setting. No need to re-start the inverter.
7.Battery Charging Current Setting	
	Default: Middle
	LOW (100AH) - MIDDLE (300AH) - HIGH (600AH)
	Mark : Press Enter to enable the setting. No need to re-start the inverter.

NOTE : 1.2KVA ONLY 24VDC

